

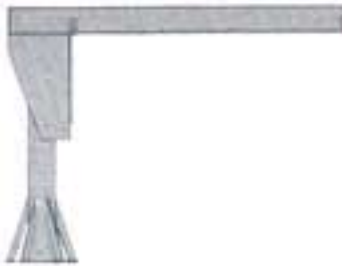

ABELL-HOWE STOCK JIBS

Our expertise in manufacturing plus our stock of components allow Abell-Howe the fastest shipment anywhere on select models of jib cranes. Refer to the following table for details.

MODEL NO.	CAPACITY TON	SPAN (FT.)	BOOM HEIGHT (FT.)	DESCRIPTION
	JB1F	1/4-1	—	Abell-Howe Jib Crane Fitting Kits permit you to make your own wall bracket or full cantilever jib cranes. JB style kits consist of upper wall bracket, lower wall bracket and tie rod jib support. FC style kits consist of an upper and lower wall bracket.
	JB2F	2	—	
	JB3F	3	—	
	JB4F	5	—	
	FC-1F	1	—	
	FC-2F	2	—	
	J-904B	1/4	10	Abell-Howe's popular self-supporting J-904B Jib Cranes are ideal for spot handling in manufacturing and assembly plants.
		1/2	12	
		1	14	
	2	12	12	
			14	12
	J-900	1/2	8	Abell-Howe's Wall Bracket Jib Crane features 200° rotation covering large work areas, yet can be swung back against the wall and out of the way when not in use.
			10	
	1	8		
		10		
			14	
	J-906FCT	1/4	8	Abell-Howe's Full Cantilever Wall Bracket Jib Crane easily mounts to building or wall column. The top mounted boom permits maximum hook height.
			10	
			12	
			14	

For further information regarding larger spans and capacities for models listed above, or for information on other Abell-Howe jib cranes and overhead material handling equipment contact your local authorized Abell-Howe crane distributor or call 1-800-366-0068 or FAX 708-366-3475.